



# COMPETITION RACE HARNESS INFORMATION

Complies with Australian / New Zealand Standard AS/NZS 2596-1995

## FEATURES AND BENEFITS OF THE APV 4 POINT (2") COMPETITION HARNESS

### 1. Buckle and Tongue:

- APVs new Competition Harnesses use the proven K12 buckle and tongue as found in most original equipment vehicle applications.
- Buckle and tongue provide smooth positive and easy engagement and release.
- Tongue is profiled to follow body contour at the point of engagement.
- The material used for the buckle and tongue can withstand temperatures from -30°C to + 100°.
- Tested and operational to over 50,000 opening cycles.
- The K12 buckle and tongue are known as "Enclosed Type" to minimize the likelihood of unintentional release.
- Ergonomic design is in compliance with Australian and New Zealand Standard AS/NZS 2596 – 1995.
- All materials meet the applicable automotive flammability and toxicity requirements.
- The K12 buckle has been tested for load conditions exceeding 18kN (3970lb).

### 2. 48mm (2") Webbing:

- APV uses polyester webbing for its harness restraints. Polyester has a much better energy conversion capability than common polyamide (Nylon) webbing specially designed to minimize the forces during the rebound phase of an accident. It does not have the "rubber band" effect associated with other webbing.
- Webbing is four panel high strength 27kN (5950 lb) plus.
- Polyester has the best resistance against UV-rays and chemicals such as solvents and acids.
- The webbing pattern prevents the strap from tangling. It also provides optimum load spreading during crash conditions due to its "memory effect" a device that keeps the webbing flat.

### 3. 50mm (2") Adjusters:

- APV uses 50mm (2") length adjusters that are compact yet strong and easy to adjust.

### 4. Sports Appearance:

- APV harnesses come in a range of three (3) webbing colors to complement or contrast your specific vehicle application and needs.

## INSTRUCTIONS FOR INSTALLATION

- The world's best harness is useless if it is not correctly installed in your car.
- Install your harness as per diagrams. If in doubt, contact the supplying dealer or APV Safety Products.
- All harness vehicle mountings must be capable of withstanding a minimum of 1,600 kg (3,525 lbs).

## WARNING

- (a) This harness should be installed by a competent mechanic at an approved restraint fitting station.
- (b) Please read the whole of the instructions for installation carefully and consult APV Safety Products in the event of doubt as to the method of installation.
- (c) This harness is not to replace your existing vehicles lap sash retractable seat belt.
- (d) The harness is not to be used for normal road use unless as part of a controlled event e.g. as arranged with your car club.
- (e) Warning: Do Not Anchor The Harness Assembly to unsound metal, wooden or plastic structures, or seats (unless the vehicle manufacturer has provided seat belt anchors on the seat).
- (f) Warning: Webbing Must Be Protected From Abrasion and Cutting by Sharp Corners and Edges.
- (g) Warning: Do Not Make Alterations or Modifications to the Harness Assembly.
- (h) Warning: Do Not Attempt to Attach Harness Straps to Existing child Restraint Anchors provided in the Vehicle.

### FOR THE FULL BENEFIT FROM THIS HARNESS

- IT MUST BE FIRMLY ADJUSTED
- IT MUST NOT BE TWISTED
- THE LAP SECTION MUST BE WORN ACROSS THE HIPS
- THE BUCKLE AND TONGUE MUST BE WORN EVENLY LEFT TO RIGHT OF THE WEARERS BODY
- THE LAP BELT PORTION MUST BE WORN AT OR BELOW THE WEARERS HIP

THE EFFECTIVENESS OF THIS HARNESS IS DIRECTLY RELATED TO THE WAY IN WHICH IT IS INSTALLED, USED AND MAINTAINED. THE USER ASSUMES THAT RISK. NO WARRANTY, EXPRESSED OR IMPLIED, IS MADE AS TO ITS ABILITY TO PROTECT AGAINST SERIOUS INJURY OR DEATH. SEE INSTRUCTION FOR CORRECT INSTALLATION. IF IN DOUBT, CONSULT THE MANUFACTURER. THE HARNESS SHOULD BE RETURNED TO THE MANUFACTURER FOR **INSPECTION ONCE PER AND REPLACED FOLLOWING AN ACCIDENT OR WHEN THE WEBBING OR HARDWARE IS DAMAGED IN ANY WAY OR DOES NOT FUNCTION PROPERLY.**

The racing harness must be used in its approved configuration without any modifications or removal of parts, and in conformity with the manufacturer's instructions and the racing regulations.

### REGULATIONS VARY – CHECK WITH YOUR GOVERNING MOTOR RACING BODY

- Inspect the harness regularly for signs of damage.
- A harness must be replaced after any severe collision, and whenever the webbing is cut, frayed or weakened due to the actions of chemicals or severe sunlight.
- It must also be replaced if any of the metal parts, buckle, anchors adjusters are bent, deformed or rusted. Any harness that does not function properly must be replaced.

Certified Product  
Australian Standards  
AS/NZS2596 ID3098



A Division of Australian Performance Vehicles • ABN 38-110-355-934 • 1509 Hume Highway, Campbellfield, Victoria 3061. Phone (03) 9355 5533, Free 1800 804 588.

Visit us at [www.apvsafetyproducts.com](http://www.apvsafetyproducts.com)

# COMPETITION RACE HARNESS INFORMATION CONT'D

## EYE BOLTS: (For Harnesses with Quick Release Anchors Only)

- Ensure eyebolts are tight in their mountings and in line with direction of load (Fig.A1).
- The initial adjustment of the shoulder straps should be carried out at the time of installation.
- Where the vehicle has no in-built anchors with weld nuts, the plate, nut and spring washer can be used (Fig. A2).

## FIXED END BOLTS: (For Harnesses with Fixed Anchors Only)

- Ensure eyebolts are tight in their mountings and in line with direction of load (Fig.A1).
- The initial adjustment of the shoulder straps should be carried out at the time of installation.
- Where the vehicle has no in-built anchors with weld nuts, the plate, nut and spring washer can be used (Fig. A3).

## APV COMPETITION RACE HARNESS LAID OUT

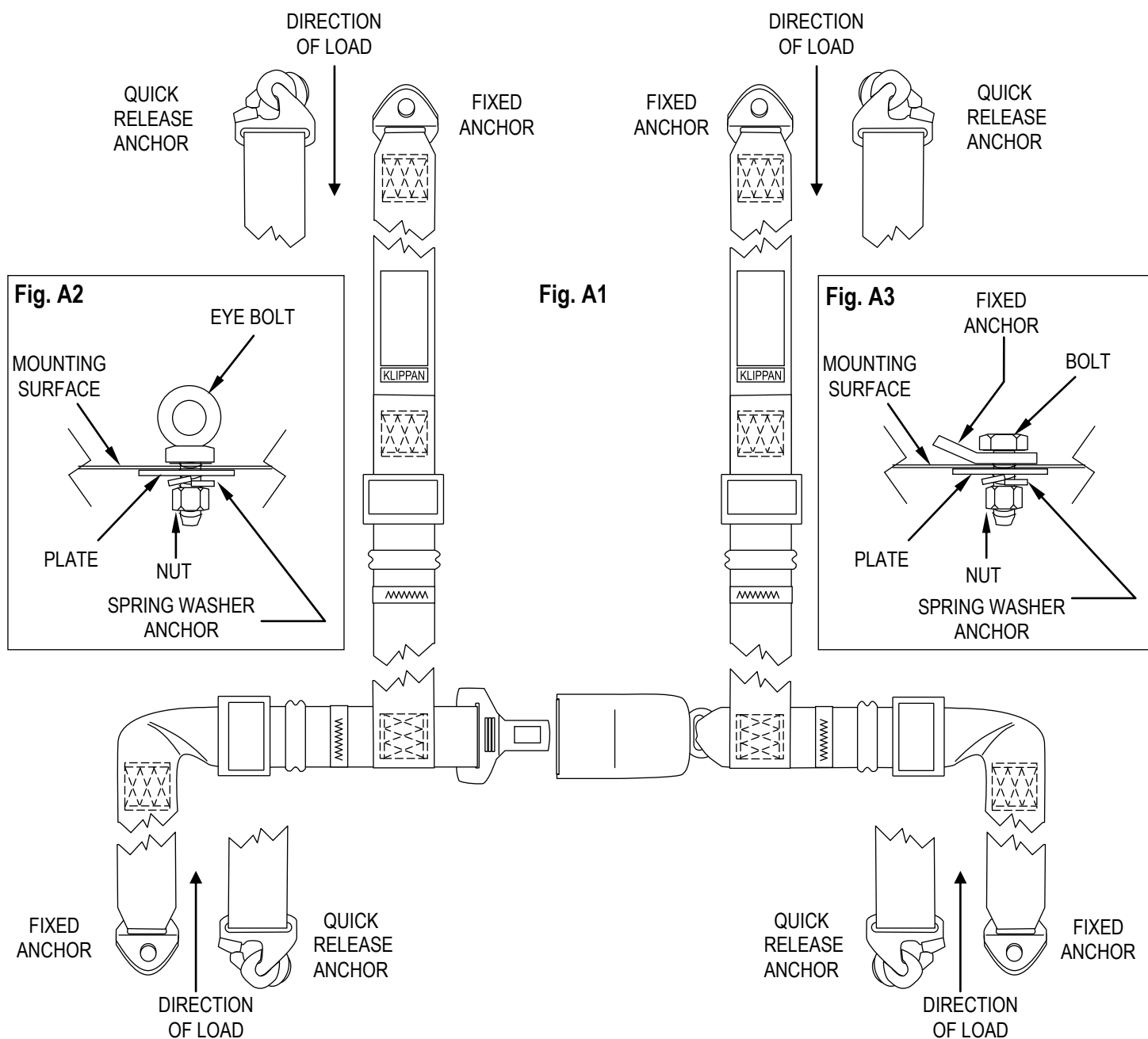

# COMPETITION RACE HARNESS INFORMATION CONT'D

## SHOULDER STRAPS

- The recommended mounting position for the shoulder straps is to the section directly behind the occupant to the rear parcel shelf of the vehicle. **Fig C**
- Have your vehicle parcel shelf checked to ensure that it is in should order and able to withstand the loadings typical of an accident situation.
- Where your harness is equipped with quick release anchors, your harness can be removed from the vehicle.
- Do not mount shoulder straps on floor directly behind the occupant's seat. The seat may give way in a severe impact, forcing the belt to compress the spine when the occupant is thrown forward. **Fig D**

With the occupant in the normal seated position adjust the rear-most portion of the shoulder straps so that the two shoulder strap adjusters rest on the occupant's chest approximately 25cms from the release buckle. This is done as follows:

1. With Quick Release Clips – pass the webbing through the slot in the locking device, (2-bar slide), until the required length is obtained. It is important that after this adjustment has been made that the webbing is pulled tight through the locking device to remove all slack in the webbing.
- A racing harness **must not** be installed in a seat having no head restraint or having a backrest with integrated head restraint (no opening between backrest and head restraint).
  - The harness belts must remain routed so as to pass smoothly over the top of the shoulders.
  - **Never** have any slack in your shoulder harnesses. The whiplash effect can cause serious neck injuries.
  - When shoulder harnesses are mounted on the rear parcel shelf or similar area, shoulder harness straps should be crossed over to help reduce the risk of your shoulders slipping out under impact. **Fig E.**

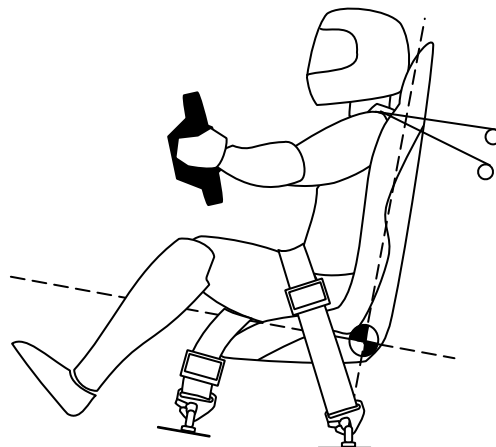

Ideal shoulder harness length & mounting position.  
**Fig. C**

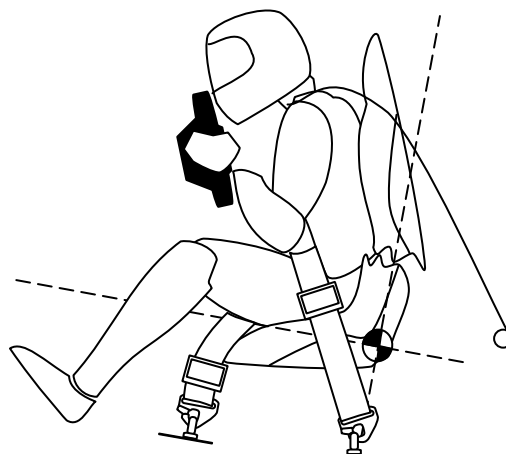

Incorrect mounting position and length.  
**Fig. D**

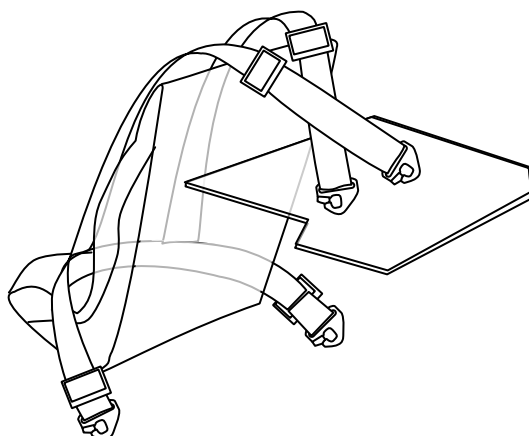

"Cross over" Shoulder belts  
**Fig. E**

# COMPETITION RACE HARNESS INFORMATION CONT'D

## LAP & CROTCH STRAPS

- The lap and crotch straps should pass through the racing seat openings without twisting, or over the side of an automotive style seat in order to wrap and hold the pelvis region over the greatest possible surface. The lap straps must fit tightly in the bend between the pelvis crest and the upper thigh. **UNDER NO CIRCUMSTANCES MUST THEY BE WORN OVER THE REGION OF THE ABDOMEN.**
- Holes may be made in this series seat if this proves to be necessary in order to avoid this occurrence. Care must be taken so that the straps cannot be damaged through chafing against sharp edges.
- When wearing the harness adjust all straps to be as tight as possible without being uncomfortable.
- Tighten lap straps first then crotch and shoulder straps.

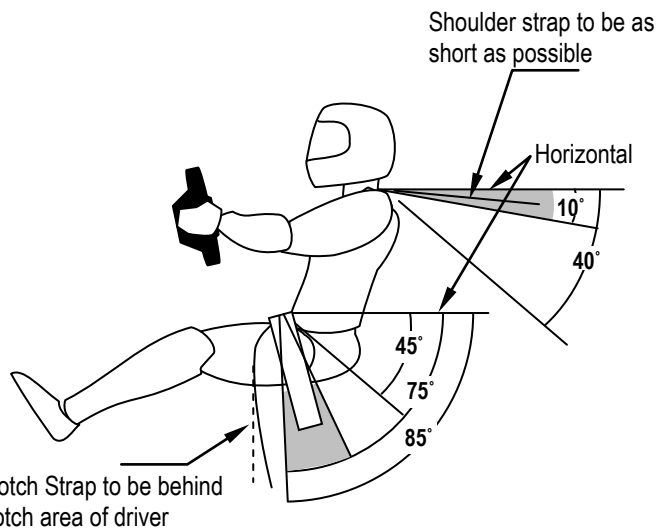

- Recommended range of angles for Safety Harness belts
- Acceptable range of angles for Safety Harness Belts. Note that the angles are taken for the driver's body, not the slots in the seats.

Fig. E

## MOUNTING LOCATIONS

- The recommended geometrical locations of the anchorage points are shown in Fig F. In the downward direction, the shoulder straps must be directed towards the rear and must be installed in such a way that they do not make any angle of more than 45 degrees to the horizontal from the upper rim of the backrest. **It is recommended that this angle should not exceed 10 degrees.**

The maximum angles in relation to the centre-line of the seat are 20 degrees divergent or convergent as shown in Fig G. If possible, the anchorage point originally mounted by the car manufacturer on the C-Pillar should be used.

The racing harness must be used in its approved configuration without any modifications or removal of parts, and in conformity with the manufacturers' instructions and the racing regulations.

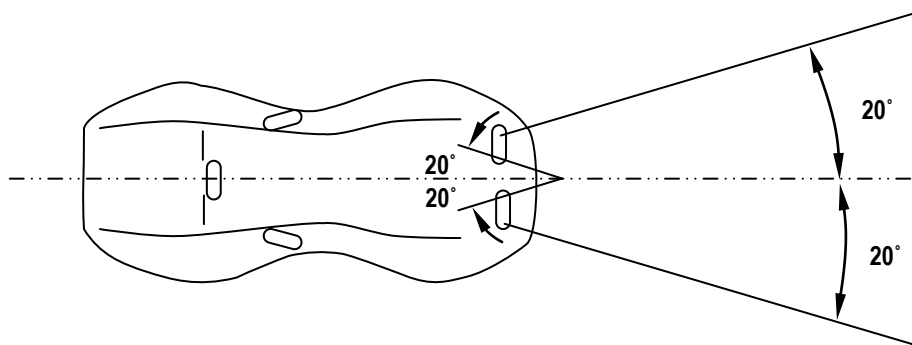

Fig. G